

**SmartGuard®**

# **Walk Through Metal Detector**

E – 6 0 0 6 / S E – 1 8 0 6 / S E – 3 3 0 6

## **User Manual**

**polimek®**

**Polimek Electronics and Computer Industry Inc.**

Atatürk Organized Industrial Zone 10024 St. No: 9 Cigli-Izmir /TURKEY

Tel: +90 [232] 328 1645 (pbx) – Fax: +90 [232] 328 1674 Whatsapp: +90 [532] 498 3402

[www.smartguard.com.tr](http://www.smartguard.com.tr) – [www.polimek.com.tr](http://www.polimek.com.tr) Email: ekin.polat@polimek.com.tr

## Contents

<b>【NOTES】</b> .....	1
<b>【PRODUCT SPECIFICATION】</b> .....	2
<b>【INSTALLATION ENVIRONMENT】</b> .....	3
<b>【PERFORMANCE AND FEATURES】</b> .....	4
<b>【PARTS】</b> .....	5
<b>【INSTALLATION】</b> .....	6
<b>【CONTROL PANEL】</b> .....	7
<b>【DETECTION ZONES】</b> .....	7
<b>【OPERATION】</b> .....	8
<b>【PASSWORD MANAGEMENT】</b> .....	13
<b>【OPTIONAL FUNCTIONS】</b> .....	13
<b>【DETECTION ADJUSTMENT】</b> .....	14
<b>【FAQ】</b> .....	15
<b>【TECHNICAL PARAMETERS】</b> .....	16
<b>【FACTORY PARAMETERS】</b> .....	17
<b>【PACKING LISTING】</b> .....	17
<b>【WARRANTY CARD】</b> .....	18

## **【NOTES】**

**PLEASE READ THE FOLLOWING INSTRUCTION CAREFULLY BEFORE OPERATION:**



1. It's available for indoor use, if need to use outdoor, please use canopy to protect it against rain.
2. Choose the smooth and stable installation place, to avoid false alarm caused by the wagging.
3. Make sure the position of the left and right detector heads in the panels are correct before installation.
4. It will have a 1 minute self-inspection after power-on, to achieve the excellent performance.
5. The passers must abide by the predefined standby time and alarm time ( $>1$  s) when checking, walking through one by one, do not crowded around the detector to interfere with infrared induction.
6. Don't knock and crash the detector during security checking to avoid false alarm, even the damage.
7. Do not disassemble the HV control units except the professional technician to avoid the artificial accident.
8. Detector can be repaired free with the warranty card attached the goods if under the warranty.

## 【PRODUCT SPECIFICATION】

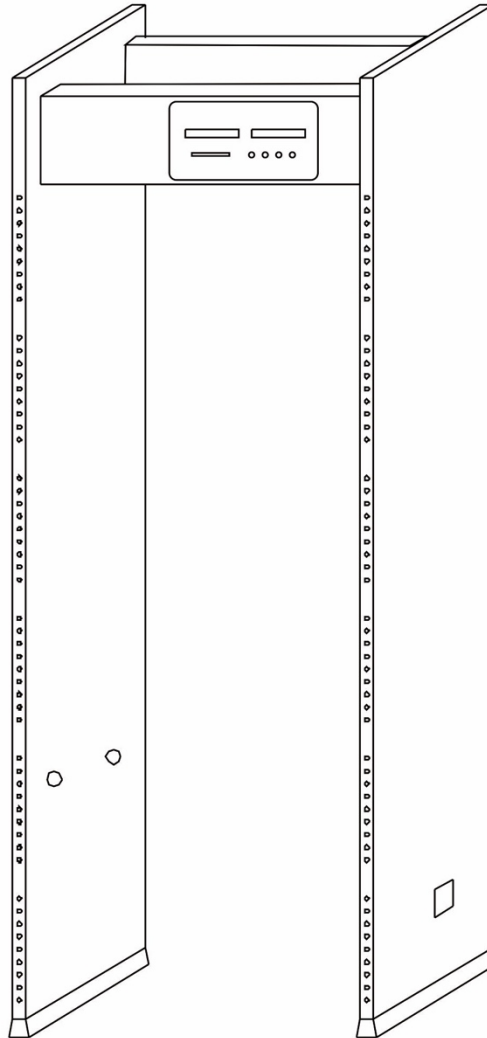

Walk through metal detector is a stationary-mounted detection equipment, or WTMD for short, mainly used to check the metal objects hidden in human body. When the passers walk through the WTMD, it will alarm and display the alarm zone at once, if the metal size in human body is more than the predefined metal parameter of weight, quantity or shape, so that security staff can find the person with prohibited metal objects in time.

As one of the the highest technical domestic products to meet the needs of users in various industries. Our WTMD are in strongest ability of induction and detection, higher sensitivity, stronger anti-interference,

## **【INSTALLATION ENVIRONMENT】**

### **1. Stationary Metallic Items**

When installing the WTMD, it should stay away from the stationary or fixed bulk metal items 2 meters; otherwise it will affect the sensitivity and cause false alarm. Metal items such as: aluminum alloy / stainless steel doors and windows, with reinforced wall, etc.

### **2. Movable Metallic Items**

The big metal items can be moved, should stay away from the device about 5 meters to avoid false alarm. Especially install the detector at factory gate or ground floor, need to pay attention to the effect of rolling gate, iron security doors, elevators and cars on the detector.

### **3. Floor Vibration**

The floor should be flat and fixed, to avoid false alarm after installation by the movement of people walking or moving and shaking of metal objects.

### **4. Electromagnetic Radiation And Electromagnetic Interference**

Because the device uses bilateral transceiver technology, therefore, any electromagnetic interference sources and electromagnetic radiation source are not allowed to close the device, the recommended distance is 1~2 meters. The parameters of the distance are determined by the installation environment, and different installation environments with different parameters.

The electromagnetic interference sources and electromagnetic radiation sources as following:

Electrical Control Box, Radio Equipment, Interphone, Electronic Computer And Peripheral Equipment, Video Monitor, High Power Motor, Power Transformer, Ac Power Lines, Thyristor Control Circuit (High Power Switching Power Supply, Inverter Welder), Engine, Motor etc.

### **5. Side-By-Side Using(more than 2 pieces WTMD)**

When installing the WTMD side by side more than 2 pieces, there will be a certain degree of influence between each WTMD, it is related to the distance and the frequency between WTMD. The distance between 2 WTMDs can not be less than 50cm. Specific distance parameters according to the actual environment and the selection of the work frequency to adjust.

**6. Can not install the device in windy place. It would cause of false alarm if the device would slight swing in the wind.**

## **【PERFORMANCE AND FEATURES】**

**Accurate Positioning:** 6/18/33 overlapping network detection zone, bilateral transmit and receive, can be accurately positioned to the detected objects, intuitively display of the target location.

**Micro Processor Technology:** the scanning electromagnetic wave generated by the microcomputer control circuit, the scanning rate can be precisely controlled. All the parameters can be set through the control panel as needed to ensure the sensitivity with flexibility, reliability, stability.

**Sensitivity Adjustable:** each detection zone has 100 sensitivity level (0 ~ 99). Preset metal size, you can exclude the coins, keys, jewelry, belt buckle etc.

**Digital Pulse Technology:** Digital Signal Processing(DSP) and filtering system, has excellent anti-interference ability.

**Password Protection:** only the correct password can change the sensitivity and other parameters. Password with five digits, can be set by the user.

**Count Statistics:** pass count and alarm count.

**Harmless to Human Body:** harmless to heart pacemaker, pregnant women, magnetic floppy disk, recording tapes etc.

**Power Supply Security:** the power supply on the top of the control box, waterproof.

**Waterproof Foot Cover:** not only can fixed the device, but also waterproof.

**Waterproof:** using PVC synthetic material, special technology, waterproof, fireproof, shockproof.

**Easy to Install:** the system is integrated design, just 20 minutes to complete the installation or disassemble.

## 【PARTS】

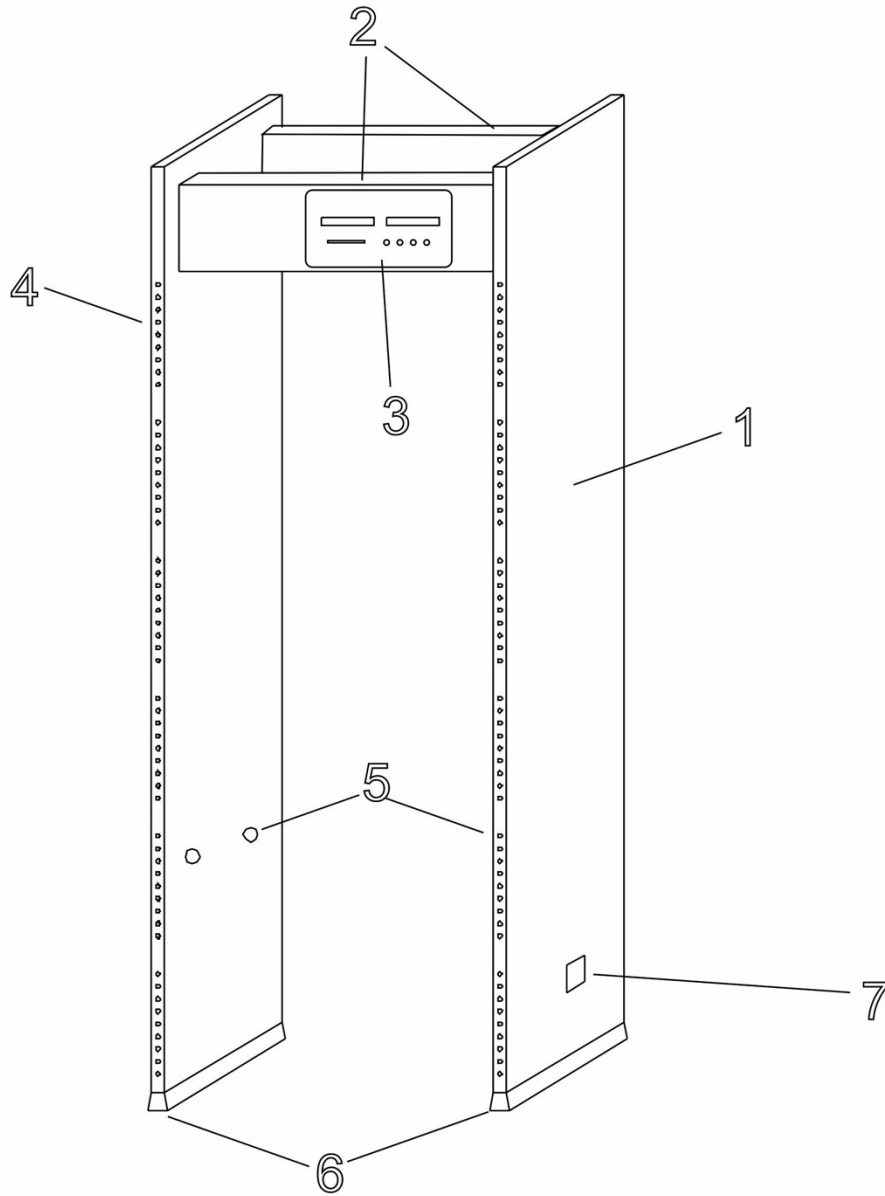

1, Door Panel 2, Crossbar 3, Integrated Host 4, Alarm zone LED 5, Infrared Sensors 6, Waterproof Foot Cover 7, Power Line&Signal line Interface

## 【INSTALLATION】

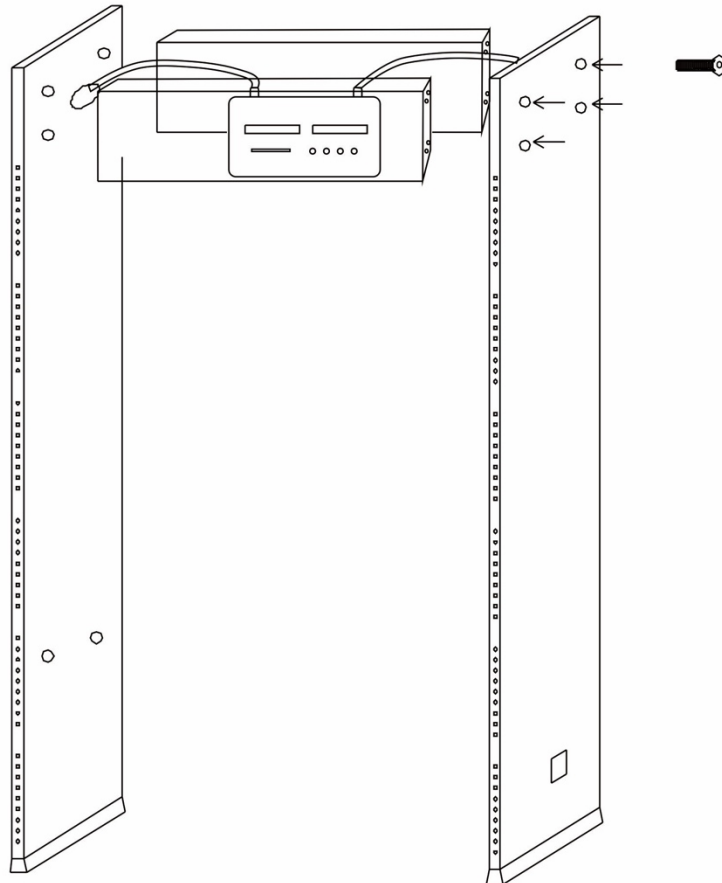

- 1.Remove the Integrated Host and the packaging of the door panels.
- 2.The main chassis display panel up, left and right side of the door as shown in the figure, then connect the left and right door to the main box respectively with bolts and nuts locked tightly.
- 3.Make sure the door probe line on the left and right were tightly inserted into the corresponding socket on the motherboard, pay attention to tighten, do not loose.
- 4.Raise the metal probe door to the vertical position and move to the specified working position.
- 5.Make the power line in the door side of connected to the power supply into the working state.



## 【CONTROL PANEL】

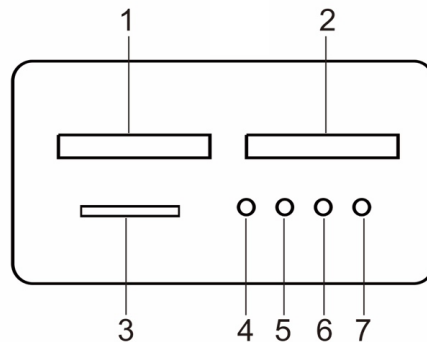

1. **LED Digital Display:** show passer number.
2. The alarm number.
3. **Interference Signal Strength Indicator:** alarm indicator (red light)
4. **"ENTER" Key:** confirm the data after setting, and use as plus key when setting the district sensitivity.
5. **"SETUP" Key:**
  - ① convert various data, and use as minus key when setting the district sensitivity.
  - ② long press 5s to adjust working frequency, 1~16 bands to choose.
6. **"SELECT" Key:** choose each program, and use as plus key when entering password .
7. **"RESET" Key:** zero clearing for number of passer and alarm.

## 【DETECTION ZONES】

A: Control Unit: signal strength indicator, the number of passer and alarm  
Standby Indication: indicator in red when alarming.

B: LED bar Alarm

As Figure-1, there are six sets of unique pinpointing LEDs, which represent six detection zones(from bottom to top 1.2.3.4.5.6).Same way for Figure-2 and Figure-3. Pinpointing LEDs have 2 states in red bright or not bright. It's in red alarm when passers' body with or exceed stated metal content,if there are multiple targets, then each target location of the LEDs will be lit with alarm sound at the same time, (Except for mute).

C: Infrared Sensor(IR)

When the power is turned on, the WTMD starts to work, the infrared sensor can effectively stop the alarm when nothing pass it to avoid false alarm. The passers could be exactly counted by IR. Regardless of any cause of the alarm in transit, he has to go through the WTMD again.

[Icon]		
6		
5		
4		
3		
2		
1		

Figure-1

[Icon]		
6	18	12
5	17	11
4	16	10
3	15	9
2	14	8
1	13	7

Figure-2

[Icon]		
11	33	22
10	32	21
9	31	20
8	30	19
7	29	18
6	28	17
5	27	16
4	26	15
3	25	14
2	24	13
1	23	12

Figure-2

## 【OPERATION】

### 6 Zone Walk Through Metal Detector

1. Long press “SELECT”3 seconds, entering“P-0”or ”P-1”mode. (“P-0” for Inspection, “P-1” for Test Flying Object or Test Mode.) Adjust to “P-0” mode and press “ENTER”to confirm entering P-0 mode.

2. Long press“SETUP” entering“Frenquency Adjustment”,will show “F-xx”. “xx”means Device Frequency Code. Press “SELECT” can adjust the Frequency. Press “ENTER” confirm the selection. In order to avoid signal interference, the frequency code of each adjacent device must be different. (For user convenient operation, we have particularly simplified the Frequencies to 16 total, which can for unlimited devices installation!)

3. Press “SELECT”, will show “12345”, which is factory original password. If have changed the original password, please input the new correct password. (For password input details please refer to “Password Management”)

4. Press “ENTER” again, will show “00000”, means password correct can go to next

setting. Or if show “E0000”, means password wrong, need input the correct password then can go to the next setting.

5. One more time press “ENTER”, will show “A-6”, means the device of 6 zones.

6. Press “SETUP”, will show “d-01”, which is alarm duration time. “01” means alarm duration of 1 second, maximum alarm duration of 3 seconds. Press “SETUP” can adjust to 01, 02, 03 second.

7. Press “SELECT”, entering Zone-Sensitivity-Level adjustment, will show “1-xxx”, (“1” means 1st zone, “xxx” means zone sensitivity level.) Press “SETUP” can reduce the zone sensitivity level, press “ENTER” can increase the zone sensitivity level. The higher the “xxx” figure, the higher the sensitivity!  
e., Adjust to “1-365”, means the 1st zone sensitivity level is 365, the detectable metal object would be a coin or a smaller metal object.

8. Again, press “SELECT” in turn, will show “2-xxx”~“6-xxx”, same as the 1st zone sensitivity adjustment, you can adjust each zone sensitivity level respectively.

9. Press “SELECT”, will show “H-xxx”, means device (whole) Sensitivity-Level is “xxx”.

10. After Zone-Sensitivity-Level finish adjustment, press “SELECT”, will show “AP”, means entered Application Mode adjustment option. Press “ENTER” to Application-Adjustment mode and press “SETUP” can adjust the application. Then press “SELECT” to confirm the selection. The higher the application code figure, the lower the sensitivity! (For user convenient operation, we have particularly simplified the Application to 6 total, which could meet all general markets requirements!)

11. Press “SELECT”, enter Volume-Level adjustment, and press “SETUP” show “yL-H”, means high volume, press “SETUP” again, show “yL-L” means low volume.

12. Press “SELECT”, will show “Id-xx”, means entered Device “ID” adjustment option, “xx” means the device ID code. (Press “ENTER” for one time can add “1” in single digits, press “SETUP” for one time can add “1” in 10-digit. Press “ENTER” “SETUP” for more times will add more respectively!)

13. Press “SELECT”, will show “A6”. Press “ENTER” then come to “Inspection Mode” and device ready to work.

14. The device will automatically display PASS COUNT & ALARM COUNT, the number of memories is 99999, press “RESET” can recount.

## 18 Zone Walk Through Metal Detector

1. Long press “SELECT” 3 seconds, entering “P-0” or “P-1” mode. (“P-0” for Inspection, “P-1” for Test Flying Object or Test Mode.) Adjust to “P-0” mode and press “ENTER” to confirm entering P-0 mode.
2. Long press “SETUP” entering “Frequency Adjustment”, will show “F-xx”. “xx” means Device Frequency Code. Press “SELECT” can adjust the Frequency. Press “ENTER” confirm the selection. In order to avoid signal interference, the frequency code of each adjacent device must be different. (For user convenient operation, we have particularly simplified the Frequencies to 16 total, which can for unlimited devices installation!)
3. Press “SELECT”, will show “12345”, which is factory original password. If have changed the original password, please input the new correct password. (For password input details please refer to “Password Management”)
4. Press “ENTER” again, will show “00000”, means password correct can go to next setting. Or if show “E0000”, means password wrong, need input the correct password then can go to the next setting.
5. One more time press “ENTER”, will show “A-18”, means the device of 18 zones.
6. Press “SETUP”, will show “d-01”, which is alarm duration time. “01” means alarm duration of 1 second, maximum alarm duration of 3 seconds. Press “SETUP” can adjust to 01, 02, 03 second.
7. Press “SELECT” entering Zone-Sensitivity-Level adjustment, will show “1L-xxx”. (“1” means 1st zone, “L” means left side zones, “xxx” means zone sensitivity level.) Press “SETUP” can reduce the zone sensitivity level, press “ENTER” can increase the zone sensitivity level. The higher the “xxx” figure, the higher the sensitivity!  
Example, adjust to “1L-365”, means the Left side 1st zone sensitivity level is 365, the detectable metal object would be a coin or a smaller metal object.  
Samely, press “SELECT” in turn, will show “2L-xxx”~“6L-xxx”, user can adjust the left side 6 zone sensitivity level respectively.
8. Then press “SELECT” again, entering right side zone settings. Will show “1R-xxx”, means right side first zone sensitivity level. Same as the “1L-XXX” zone sensitivity adjustment, user can adjust the right side 6 zone sensitivity level respectively.
9. Now “Left” & “Right” side Zone-Sensitivity-Level finish adjusting, press “SELECT” entering whole Sensitivity-Level adjustment, will show “H-xxx”.

10. After all Sensitivity-Level finish adjustment, press “SELECT”, will show “AP”, means entered Application Mode adjustment option. Press “ENTER” will show “AP-1”, means “Application 1”, press “SETUP” can adjust the application. Then press “SELECT” to confirm the selection. The higher the application code figure, the lower the sensitivity! (!For user convenient operation, we have particularly simplified the Application to 6 total, which could meet all general markets requirements!)

11. Press “SELECT”, enter Volume-Level adjustment, and press “SETUP” show “yL-H”, means high volume, press “SETUP” again, show “yL-L” means low volume.

12. Press “SELECT”, will show “Id-xx”, means entered Device “ID” adjustment option, “xx” means the device ID code. (Press “ENTER” for one time can add “1” in single digits, press “SETUP” for one time can add “1” in 10-digit. Press “ENTER” “SETUP” for more times will add more respectively!)

13. Press “SELECT”, will show “A18”. Press “ENTER” then come to “Inspection Mode” and device ready to work.

14. The device will automatically display PASS COUNT & ALARM COUNT, the number of memories is 99999, press “RESET” can recount.

### **33 Zone Walk Through Metal Detector**

1. Long press “SELECT” 3 seconds, entering “P-0” or “P-1” mode. (“P-0” for Inspection, “P-1” for Test Flying Object or Test Mode.) Adjust to “P-0” mode and press “ENTER” to confirm entering P-0 mode.

2. Long press “SETUP” entering “Frequency Adjustment”, will show “F-xx”. “xx” means Device Frequency Code. Press “SELECT” can adjust the Frequency. Press “ENTER” confirm the selection. In order to avoid signal interference, the frequency code of each adjacent device must be different. (For user convenient operation, we have particularly simplified the Frequencies to 16 total, which can for unlimited devices installation!)

3. Press “SELECT”, will show “12345”, which is factory original password. If have changed the original password, please input the new correct password. (For password input details please refer to “Password Management”)

4. Press “ENTER” again, will show “00000”, means password correct can go to next setting. Or if show “E0000”, means password wrong, need input the correct password then can go to the next setting.

5. One more time press “ENTER”, will show “A-33”, means the device of 33 zones.  
6. Press “SETUP”, will show “d-01”, which is alarm duration time. “01” means alarm duration of 1 second, maximum alarm duration of 3 seconds. Press “SETUP” can adjust to 01, 02, 03 second.

7. Press “SELECT” entering Zone-Sensitivity-Level adjustment, will show “1L-xxx”. (“1” means 1st zone, “L” means left side zones, “xxx” means zone sensitivity level.) Press “SETUP” can reduce the zone sensitivity level, press “ENTER” can increase the zone sensitivity level. The higher the “xxx” figure, the higher the sensitivity!

Example, adjust to “1L-365”, means the Left side 1st zone sensitivity level is 365, the detectable metal object would be a coin or a smaller metal object.

Samely, press “SELECT” in turn, will show “2L-xxx”~“11L-xxx”, user can adjust the left side 11 zone sensitivity level respectively.

8. Then press “SELECT” again, entering right side zone settings. Will show “1R-xxx”, means right side first zone sensitivity level. Same as the “1L-XXX” zone sensitivity level adjustment, user can adjust the right side 11 zone sensitivity level respectively.

9. Now “Left” & “Right” side Zone-Sensitivity-Level finish adjusting, press “SELECT” entering whole Sensitivity-Level adjustment, will show “H-xxx”, means Device whole Sensitivity-Level is “xxx”.

10. After all Sensitivity-Level finish adjustment, press “SELECT”, will show “AP”, means entered Application Mode adjustment option. Press “ENTER” will show “AP-1”, means “Application 1”, press “SETUP” can adjust the application. Then press “SELECT” to confirm the selection. The higher the application code figure, the lower the sensitivity! (!For user convenient operation, we have particularly simplified the Application to 6 total, which could meet all general markets requirements!)

11, Press “SELECT”, enter Volume-Level adjustment, and press “SETUP” show “yL-H”, means high volume, press “SETUP” again, show “yL-L” means low volume.

12. Press “SELECT”, will show “Id-xx”, means entered Device “ID” adjustment option, “xx” means the device ID code. (Press “ENTER” for one time can add “1” in single digits, press “SETUP” for one time can add “1” in 10-digit. Press “ENTER” “SETUP” for more times will add more respectively!)

13. Press “SELECT”, will show “A33”. Press “ENTER” then come to “Inspection Mode” and device ready to work.

14. The device will automatically display PASS COUNT & ALARM COUNT, the number of memories is 99999, press “RESET” can recount.

## 【PASSWORD MANAGEMENT】

### 1. Password Management

#### ***Password Enter:***

- 1) Press "SELECT" key, the panel shows "12345".
- 2) Press "SETUP" key, the panel display as "1-345", "\_" is a modify command to set number, press the "SETUP" key, "\_" can be recycled to the right.
- 3) Press "SELECT" key, as plus key when setting the password number with "\_" .
- 4) After entering the correct password, press "ENTER" key. If display as "00000", means the password is set up; If display as "E0000", means the password is wrong, need press "ENTER" key to re-enter the correct password.
- 5) Then press "ENTER" key, display as "d-01", then press "SELECT" key to enter the next step.

#### ***Password Change:***

- ① Press "SELECT" key when display as "12345", if changed the password, enter your password. Steps please refer to details of Password Enter above.
- ② If forget password, press "SETUP" → "SELECT" to change "E0000" into "88888" then press "ENTER", and display as "00000", press "SELECT" to enter the number, press "SETUP" to change next number
- 6) Enter the password to be set, press "ENTER" key, there will be "A-6" for 6-zones, "A-18" for 18-zones, "A-33" for 33-zones, press "ENTER" key, then the password is set up.
- 7) If forget password, long press "ENTER" can restore to the initial password "123456".

### 2. Zones Distinction:

- 1) **6-zones:** from bottom to the top is 1~6 zone evenly distributed.
  - ① 1~6 zone sensitivity, the sensitivity is proportional to its numeric.
  - ② "H" is overall sensitivity, the sensitivity is proportional to its numeric.
- 2) **18-zones and 33-zones:** from bottom to top is 1~18/1~33 zone evenly distributed.
  - ① 1~18/1~33 zone sensitivity, the sensitivity is proportional to its numeric.
  - ② "H-xxx" is overall sensitivity, the sensitivity is proportional to its numeric.

## 【OPTIONAL FUNCTIONS】

PC Networking, Turnstile Integration, UPS, Camera, etc.

## **【DETECTION ADJUSTMENT】**

**1. Install the Walk Through Metal Detector in a stable state could achieve the best detection results (Please refer to "Installation Environment") Below are steps for telling if the Walk Through Metal Detector is in a steady state:**

- 1) 1 minute after start up, the Walk Through Metal Detector gate is under unshaking state.
- 2) During test, there should be no alarm sound when tester passing the Walk Through Metal Detector and not carrying any metal items.
- 3) Combined with the above two situation that the Walk Through Metal Detector is in a stable state.

**2. In order to exclude the influence of small metal objects such as rings, key, belt buckle, shoes on the actual metal objects to be detected, please adjust based on the following steps:**

- 1) Take a small metal objects as sample, which is not within the (Walk Through Metal Detector) detection boundaries, such as a string of keys.
- 2) Set the sensitivity to a higher level, then let test person take the sample & pass by the walk through metal detector, and there will be alarming.
- 3) Appropriately lower the sensitivity, then take the sample & pass by the walk through metal detector once again , if there is still an alarm sound, then continue lowering the sensitivity until there is no alarm sound .

Notes:

if there is a certain detection zone needs lower the sensitivity, then only need to adjust the relevant detection zone. With the above adjustments,for any metal objects that is less than the sample will not alarm, and for the metal objects that are larger than the sample all will be accurately detected.

**3. Passing Rules.**

- 1) Draw a waiting line of 50cm away from the front or back of the walk through metal detector, so that the people being detected are queued to pass one by one
- 2) When passing the walk through metal detector, People being detected needs to place the metal objects (such as key, mobile, employee card, cigarettes, coins and so on) on the side of the walk through metal detector chute or wooden table, after passing and finish with safe inspection ,then take back their personal belongings.



## **【FAQ】**

### **1.The reason that Infrared does not count while installation.**

- 1) Please check if there is no tightening of the left and right door detection head of the main host.
- 2) Please check if there is infrared interference near the left and right side infrared head. (i.e.: infrared CCTV camera, infrared remote controller (when pressing the button), outdoor sun exposure and so on.
- 3) If there's no problem with both 1) and 2), please change and replace the infrared head.

### **2.The reason of false alarm while installation.**

1). After installed the walk through metal detector, there is frequently false alarm while testing. Firstly have a look at the installation environment, (should be no any moving or static large metal objects at the distance of 1.5M!) If there's big metal object, please try to keep the walk through metal detector away from it. Also, please pay attention if there's wind in installation area which may cause door shaking. If there's wind, suggest customer take wind protection measures or replace the installation location.

2) After installed the walk through metal detector, there is frequently false alarm while testing. ( If it is not an environmental factor, we can reduce each zones detection sensitivity first & see if there's less false alarm. But, if still high false alarm, then we need to try the following method .

a, After installed the walk through metal detector, if there are false alarm frequently while testing, (If the voltage is within the normal range, then it is necessary to replace various frequencies in the oscillation) then test again.

b, Make sure there is no Frequency Conversion Equipment working near the device. Such as, elevator that with a frequency converter, or the injection molding machine, etc., because these machines will cause serious interference to walk through metal detector while working .

c, If none of the above methods can handle the interference, suggest customer change the installation location then retry. Generally with replacement of the installation location can handle the interference problems.

## 【TECHNICAL PARAMETERS】

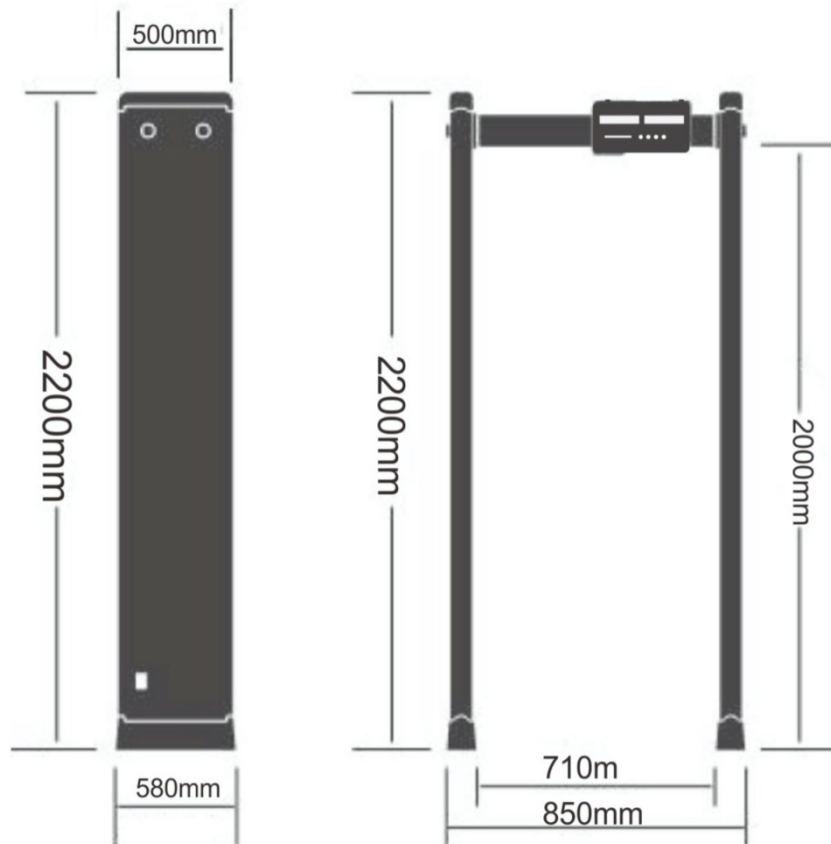

Working Voltage.....	100-240VAC
Power Frequency.....	50-60Hz
Power Consumption.....	<20W
Working Temperature.....	-10°C~45°C
Dimension.....	MM
External Height.....	2200
External Width.....	850
Internal Height.....	2000
Internal Width (Standard).....	710
Depth.....	500
Weight.....	52KG

## 【FACTORY PARAMETERS】

### 6 Zones Walk Through Metal Detector

Product Name	Walk Through Metal Detector
Alarming Time	1 second
Sensitivity(1-6 detection zones)	99
Menu Password	12345

### 18 Zones Walk Through Metal Detector

Product Name	Walk Through Metal Detector
Alarming Time	1 second
Sensitivity(1-18 detection zones)	99
Menu Password	12345

### 33 Zones Walk Through Metal Detector

Product Name	Walk Through Metal Detector
Alarming Time	1 second
Sensitivity(1-33 detection zones)	99
Menu Password	12345

## 【PACKING LISTING】

Thank you for purchasing our Walk Through Metal Detector. Please check and make sure that the following items are available in the box. If any items are missing or damaged, please contact us.

Hexagon tool    8 sets of bolt    Instructions    Power cord

## 【WARRANTY CARD】

- 1, Please keep this card and present it at the time of repair
- 2, The card will not have the warranty effect without the company's signature,
- 3, The incomplete warranty card will regard as invalid. While purchasing please confirm the warranty card and receipt and make sure all information filled are correct and detailed, and send to us for better services.
4. If card loss will not reissued.

Warranty Card

Product Model	
Product Code	
Purchasing Date	
User Contact	
Postal Code	
Address	
User Tel.	
Fax	

Maintenance records

Date	Records	Maintenance staff